

Atmos

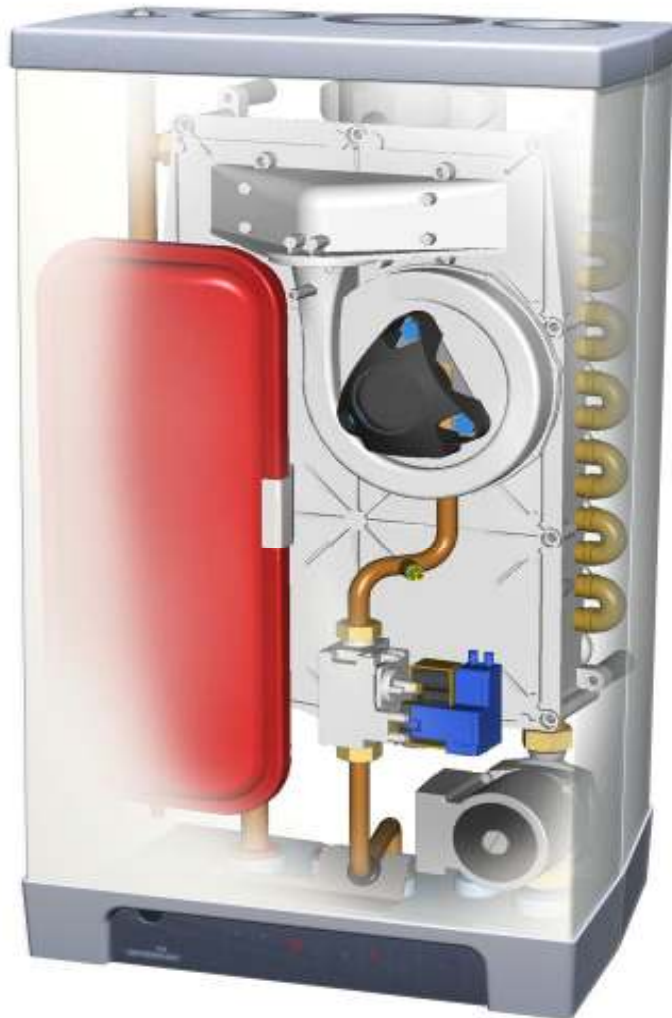

InterSystem



Installation & Servicing Instructions for HE26 & HE40C

(GC 41-249-05 & GC 41-249-07)

Atmos Heating Systems

West March

Daventry

Northants, NN11 4SA

Tel: 01327 871990

Fax: 01327 871905

e-mail: sales@atmos.co.uk

internet: www.atmos.co.uk

Issue 01.11.11 (Main revision)

© 2011 Atmos Heating Systems

The information provided applies to the product in the standard model. Atmos Heating Systems can therefore not be held liable for any damage resulting from the product specifications that deviate from the standard model.

The information provided has been compiled with the utmost care. However, Atmos Heating Systems cannot be held liable for any faults in the information nor for the consequences thereof.

Atmos Heating Systems cannot be held liable for any damage resulting from the activities carried out by third parties.

To be changed without prior notice

Building Regulations and the Benchmark Checklist

Building Regulations (England & Wales) require notification of the installation of a heating appliance in a dwelling to the relevant Local Authority Building Control Dept. This can be achieved via a Competent Persons Self Certification Scheme as an option to notifying the Local Authority directly. Similar arrangements apply in Scotland and Northern Ireland.

Atmos Heating Systems is a member of the Benchmark Scheme and the Benchmark Checklist is included at the back of these Instructions. The Benchmark Checklist provides a Commissioning Checklist and Service Record to be completed by the Installer/ Service Engineer.

Benchmark places responsibilities on both manufacturers and installers. The purpose is to ensure that customers are provided with the correct equipment for their needs, that it is installed, commissioned and serviced in accordance with the manufacturer's instructions by competent persons and that it meets the requirements of the appropriate Building Regulations. The Benchmark Checklist can be used to demonstrate compliance with Building Regulations and should be provided to the customer for future reference.

Installers are required to carry out installation, commissioning and servicing work in accordance with the Benchmark Code of Practice which is available from the Heating and Hotwater Industry Council who manage and promote the Scheme. Refer to www.centralheating.co.uk for more information.



TABLE OF CONTENTS

1. Safety Regulations	7
1.1 General	7
1.2 CH system.....	7
1.3 Gas system	7
1.4 Electrical system	7
1.5 Domestic water system.....	7
1.6 Flue discharge and air supply	7
2. Description of the Appliance	8
2.1 General	8
2.2 Operation	8
2.3 Operating conditions	8
2.4 PC interface	10
2.5 Test programmes.....	10
3. Main Components	11
3.1 Accessories.....	12
4. Installation	13
4.1 Overall dimensions HE26.....	13
4.2 Overall dimensions HE40C.....	14
4.3 Unpacking the appliance.....	15
4.4 Additional dimensions	15
4.5 Boiler location.....	16
4.6 Mounting	17
4.7 Mount the appliance.....	18
4.8 Fit the pipework cover (optional only for HE26)	18
4.9 Condensate disposal.....	19
5. Connections	20
5.1 Connect the CH system	20
5.2 Connecting the gas supply.....	21
5.3 Electrical connection	22
5.4 General Flue Requirements	25
5.5 Flue discharge and air supply	26
5.6 Roof outlet prefabricated chimney	32
5.7 Atmos MS System.....	33
5.8 Atmos Communal Flue System (CFS).....	34
6. Commissioning	35
6.1 Fill and de-aerate the appliance and the system	35
6.2 Commissioning of the appliance	36
6.3 System Shutdown	37
7. Setting and Adjustment	38
7.1 Directly via operating panel.....	38
7.2 Settings through the service code.....	38
7.3 Parameters.....	39
7.4 Setting maximum CH power	40
7.5 Setting pump position.....	40
7.6 Weather-dependent control.....	41
7.7 Conversion to other gas type	41
7.8 Gas-air control.....	41
7.9 Setting gas-air control	42
7.10 Carbon monoxide : carbon dioxide ratio (CO/CO ₂ ratio).....	43
8. Faults	44
8.1 Display last fault code.	44
8.2 Burner does not ignite	45
8.3 Burner ignites with much noise	45
8.4 Burner resonates.....	46

8.5	No heating (CH).....	46
8.6	Reduced output.....	47
8.7	CH does not reach the correct temperature.....	47
9.	SERVICING THE BOILER AND COMPONENT REPLACEMENT	48
9.1	SERVICING THE BOILER.....	48
9.2	COMPONENT REPLACEMENT.....	49
10.	Technical Specifications	52
10.1	Electrical diagram HE26.....	53
10.2	Electrical diagram HE40C.....	54
11.	CE Declaration	55

NOTE The Benchmark Checklist & Service Record are included at the back of the Manual.

This manual

Using this manual you can safely install and maintain this appliance.
Carefully follow the instructions.

In case of doubt, contact Atmos Heating Systems.

Keep these instructions near the appliance.

Abbreviations and names used

Description	To be referred to as
High Efficiency	HE
Atmos InterSystem wall-mounted gas heater	Appliance
Appliance with piping for central heating	CH system

Icons

The following symbols are used in this manual:-



CAUTION

Procedures that, when not carried out with due care, may result in damage to the product or the environment or in personal injury.

Service and technical support

For information about specific adjustments, installation, maintenance and repair activities, please contact:

Atmos Heating Systems,
West March,
DAVENTRY,
Northants, NN11 4SA
Tel: 01327 871990; fax: 01327 871905
Email: sales@atmos.co.uk; internet: www.atmos.co.uk

Environment



When the appliance needs replacement, your installer may arrange for disposal. Should this not be possible, then make enquiries with your local council about the possibilities for re-use or environmental-friendly processing of the materials used, or contact a scrap dealer about disposal.

Various plastics and metals have been used in producing the appliance. Also, the appliance contains electronic components that are electronic waste.

Intended use

The appliance as described in this documentation is intended for heating rooms with a central heating system and, if required, heating hot water via an indirect hot water tank. Any other use is outside the scope of intended use for this appliance. Any liability for damage resulting from improper use shall not be accepted.

Atmos Warranty – Short version

1. Atmos Warranty covers any material, construction or operation faults that are found to be of original manufacturing origin. A full statement of the Atmos Warranty can be found on www.atmos.co.uk.
2. Atmos boiler warranty is two years from date of invoice or 12 months from date of installation, whichever is the later. This warranty covers the cost of replacement parts and associated labour. However the ignition & ionisation probe and the glass fuse are excluded from this warranty. The warranty for the heat exchanger is 10 years in total, but this covers the cost of associated labour only for the first two years from date of invoice.
3. There is no carriage charge for the delivery of replacement parts covered by the warranty. Any alleged faulty part must be returned to Atmos carriage prepaid. Carriage will be credited if the fault is found to be a manufacturer's fault.
4. The serial number of the boiler must be supplied with any warranty claim.
5. All products must be used in an appropriate application and manner. This includes, but is not limited to, correct boiler sizing, system design, system cleansing and use of corrosion inhibitors. If the boiler installed is a combi boiler, an approved water conditioner device must be fitted in areas where the water hardness exceeds 200ppm, as required by Building Regulations.
6. The Benchmark Checklist & Service Record, found in the back of the installation Instructions, must be filled in. Failure to install and commission according to the manufacturer's instructions and complete the Benchmark Commissioning Checklist invalidates the warranty.
7. The Warranty card must be completed and the signed Atmos copy must be received within 14 days of installation together with a copy of the Benchmark Commissioning Checklist, completed by the installer. By signing the Warranty card the buyer agrees that the goods have been delivered in a satisfactory condition.

Exceptions

8. In the event of full payment for a product not being received, Atmos shall be discharged from all further contractual or warranty obligations.
9. Surface and/or transport damage are outside the scope of this warranty.
10. Any warranty provision shall not apply if Atmos determines that the fault is due to improper application, use, neglect, accidental damage or injudicious treatment, non-observance of instructions contained in Atmos Manuals or due to improper repair, adjustment, installation or maintenance or due to work carried out by unqualified engineers. The warranty also lapses if the Atmos boiler has not had a yearly service in accordance with instructions.
11. This warranty shall not apply if the fault is caused by scale, failure or abnormality of gas or water supply, or impact of any external influence that adversely affects the normal operation of the product. This shall include but not be restricted to dehydration, abnormal or high voltage, and hard water.
12. Excluded parts are the ignition & ionisation probe and the glass fuse as these are subject to wear and tear in normal use.

1. SAFETY REGULATIONS

The appliance must be installed by a Gas Safe registered person in accordance with the current Gas Safety (Installation and Use) Regulations. Failure to install appliances correctly could lead to prosecution.

Atmos Heating Systems does not accept any liability for damage or injury caused by not (strictly) observing the current safety regulations and instructions, nor by negligence while installing the Atmos InterSystem wall-mounted gas heater and any accompanying accessories.

The manufacturer's instructions must NOT be taken as overriding statutory requirements.

The regulations are mentioned separately for the different disciplines.

1.1 General

The entire system should comply with the valid (safety) regulations, as mentioned in:-

- This installation manual.
- Gas Safety (Installation and Use) Regulations
- The appropriate Building Regulations.
- Health and Safety Document No 635 (Electricity at Work Regulations)
- The Water Fittings Regulations or local Water byelaws.

1.2 CH system

The entire system should comply with the valid (safety) regulations, as mentioned in:-

- BS 5449 Central Heating for Domestic Premises.

1.3 Gas system

The entire system should comply with the valid (safety) regulations, as mentioned in:-

- BS 6798 Specification for installation of gas fired hot water boilers of rated input not exceeding 60 kW.
- BS 6891 Installation of low pressure gas pipework installations up to 28mm (R1).
- I.S.813 Installation of Gas Appliances (for installations in Ireland).
- British Gas Guidance Notes for the Installation of Domestic Gas Boilers.

1.4 Electrical system

The entire system should comply with the valid (safety) regulations, as mentioned in:-

- BS 7671 The IEE Wiring Regulations.

1.5 Domestic water system

The entire system should comply with the valid (safety) regulations, as mentioned in:-

- BS 5546 Installation of gas hot water supplies for domestic purposes.

1.6 Flue discharge and air supply

The flue discharge and the air supply system should comply with:-

- BS 5440 Flues and Ventilation for gas appliances of rated input not exceeding 60 kW. (Part 1 Flues and Part 2 Ventilation).

2. DESCRIPTION OF THE APPLIANCE

2.1 General

The Atmos InterSystem wall-mounted gas boiler is designed for delivering heat to the water of a CH system and, if required, heating hot water via an indirect hot water tank.

The air supply and flue discharge can be connected to the appliance by means of two separate pipes or a concentric connection.

The appliance has its own wall mounting strip, but can also be fitted to an optional wall mounting frame that allows top connections. An optional pipe mounting bracket for use with the wall mounting strip is available. These are supplied separately.

The Atmos InterSystem wall-mounted gas boiler has the CE quality mark and IP44 Protection class.

The appliance as delivered is suitable for natural gas (G20). A conversion kit for propane (G31) can be supplied upon request.

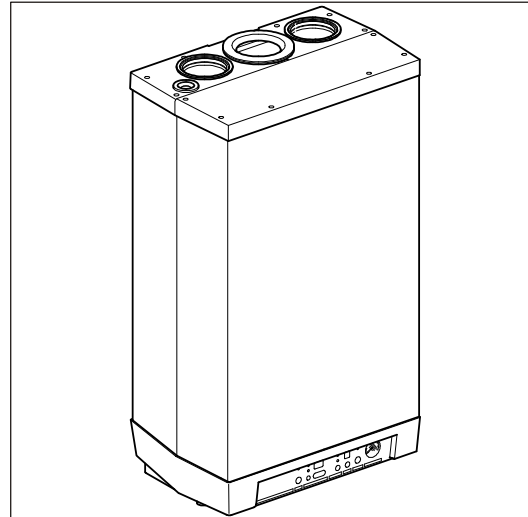

2.2 Operation

The Atmos InterSystem wall-mounted gas heater is a modulating high efficiency boiler. This implies that the power is adjusted to the heat demand.

In the aluminium heat exchanger is an integrated copper circuit.

The appliance has been provided with an electronic controller that controls the fan with the heat demand from the heating system or the hot water tank, opens the gas valve and ignites the burner, continuously monitors the flame and controls it dependent on the power required.

2.3 Operating conditions

A code indicates the operating condition of the appliance on the service display of the operating panel.

Off

The appliance is not operating, but there is electrical power. There is no response to any demand for CH (heating or hot water tank). The frost protection is active though. This means that the pump starts running and the heat exchanger is heated when the temperature of the heat exchanger drops to 5°C.

When the frost protection is activated, code 7 appears (heating of the heat exchanger).

Waiting position

The LED of the on/off button is on. The appliance is ready for responding to the demand for CH (heating or hot water tank).

0 Pump overrun

After CH operation the pump has an overrun. This overrun time is set to the value according to parameter 8 (see §7.3; factory setting is 1 min). This setting can be changed. Also, the controller will automatically run the pump for 10 seconds, once every 24 hours, to prevent it from getting stuck. This activation of the pump takes place at the time of the last heat demand 24hrs later. In order to change this time, set the room thermostat higher for a while at the desired time.

1 Required temperature reached

The controller can temporarily block the heat demand and stop the burner. This blocking takes place because the required temperature has been reached. When the temperature has dropped sufficiently, the blocking is cancelled.

2 Self-test

The controller regularly checks the connected sensors. During the check, the controller does not carry out any other tasks.

3 Ventilate (Fan)

On starting, the fan is first brought to the starting speed. When the starting speed has been reached, the burner is ignited. Code **3** is also visible after stopping the burner, when post-purge takes place.

4 Ignite

When the fan has reached the ignition speed, the burner is ignited by means of electric spark ignition. During ignition the code **4** appears. If the burner is not ignited, another ignition attempt is made after about 5 seconds. If the burner has still not fired after the fourth ignition attempt, the controller indicates a fault. See §8.

5 CH operation

An on/off thermostat can be connected to the controller, if necessary in combination with an outside sensor. See the Electrical diagram §10.1 and §10.2. When heat is demanded by a thermostat signal, the fan runs (code **3**) and the burner is ignited (code **4**), followed by the CH operating condition (code **5**).

During CH operation, the fan speed and hence the power of the appliance is adjusted. This is done in such a way, that the temperature of the CH water is controlled towards the set CH supply temperature. In the case of an on/off thermostat, the CH supply temperature is set at the operating panel. In the case of an outside sensor, the CH supply temperature is determined by the weather dependent control programmed in the controller.

During CH operation, the demanded CH supply temperature is displayed on the operating panel.

During CH operation, the actual CH supply temperature can be read by pressing the service button.

Note: Instead of an on/off thermostat, an OpenTherm thermostat can be connected to the controller as described in §5.3.1. In this case, the desired CH temperature is set by the thermostat. The minimum temperature and the operation mode can be set with parameters [E] and [E.] (refer to §7.3).

2.4 PC interface

The controller has an interface for a PC. With a special cable and accompanying software, a PC can be connected. This provision makes it possible to follow the behaviour of the controller, the appliance and the heating system during a long period.

2.5 Test programmes

In the controller, there is provision for putting the appliance into a test status.

By activating a test programme, the appliance will become active with a fixed fan speed without intervention of the control functions. The safety functions remain active though.

Simultaneously press + and – to switch off the test programme.

Test programmes

Description of programme	Button combinations	Display reading
Burner on with minimum CH power	"service" and "-"	"L"
Burner on with maximum CH power	"service" and "+" (1x)	"h"
Burner on with maximum power (set by parameter 4)	"service" and "+" (2x)	"H"
Switch off test programme	"+" and "-"	Current operating condition

2.5.1 Frost protection

The boiler has provision for protecting its heat exchanger as described below.

NOTE! However to avoid the condensate freezing, the boiler must be installed in a FROST-FREE room.



- In order to avoid freezing of the appliance (heat exchanger), it has an appliance frost protection. When the temperature of the heat exchanger drops to 5°C, the burner will be activated and the pump will start running until the temperature of the heat exchanger reaches 10°C. Code 7 is given when the appliance frost protection intervenes (heating heat exchanger).
- When the system (or a part thereof) can freeze, a frost thermostat should be installed in the area to be protected. Connect this according to the wiring diagram. See §10.1 and §10.2.

Remark

When the appliance is out of action (- on the service display), the appliance frost protection is still active. However, there will be no response to heat demand from an (external) frost thermostat.

3. MAIN COMPONENTS

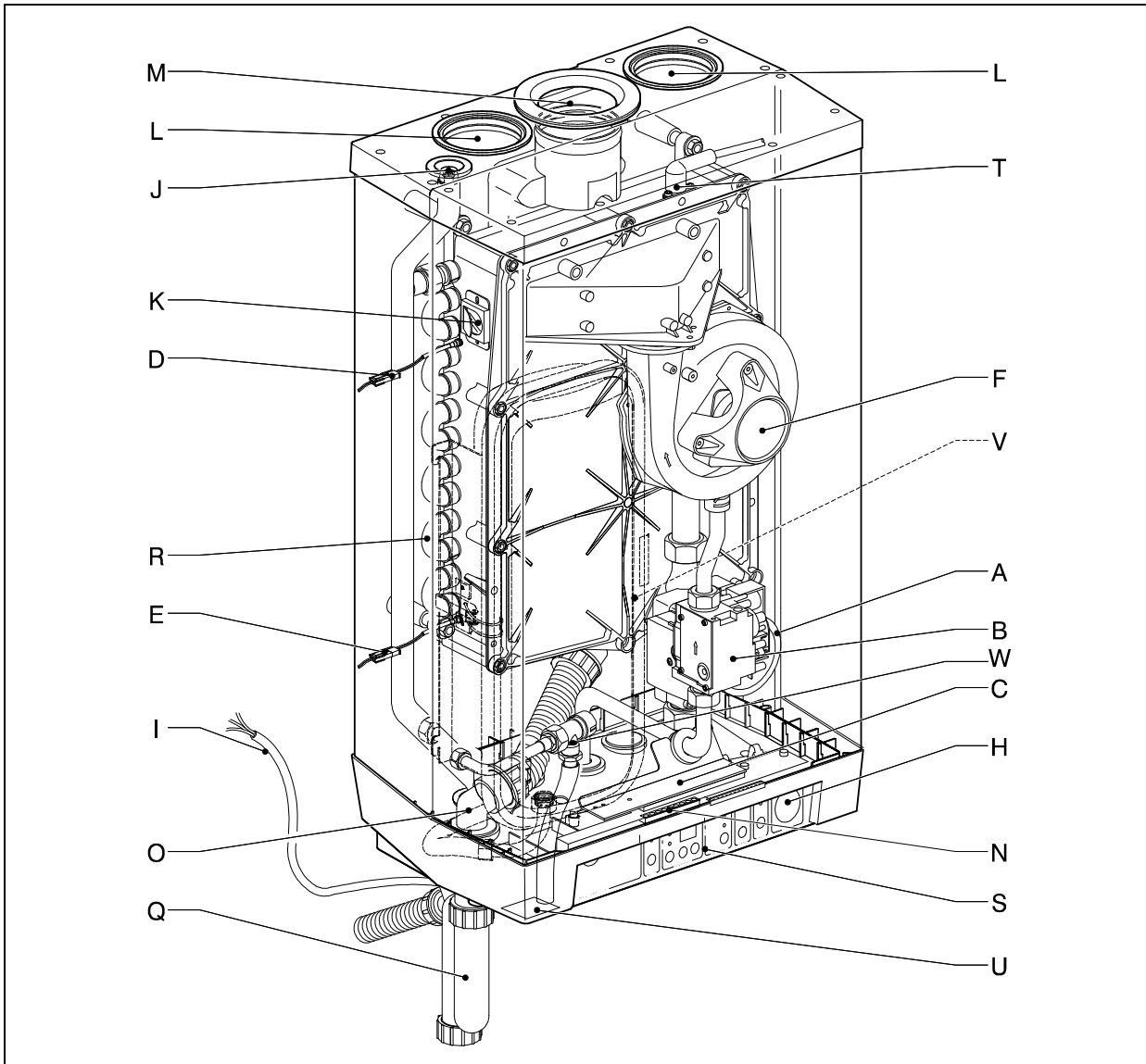

A	CH pump	M	Flue discharge (or concentric connection)
B	Gas valve	N	Connecting block / terminal list X
C	Clamping plate	O	Condensate discharge
D	Supply sensor S1	Q	Codensate trap
E	Return sensor S2	R	Heat exchanger
F	Fan	S	Controller operating panel and display
H	Pressure gauge	T	Ionisation/ignition probe
I	1m connecting cable 230 V ~	U	Position type plate
J	Manual air vent	V	Expansion vessel (shown in broken lines, HE26 only) The HE40C does not have an expansion vessel
K	Sight glass and mirror	W	Pressure relief safety valve, 3 bar
L	Air supply (left or right)		

Additional Components supplied :-

Valve set (supplied separately with boiler)

3.1 Accessories

Description	Part Ref
Pipe mounting bracket <ul style="list-style-type: none"> • Connection supply and return 22 mm diameter • Connection gas ½" female thread • Mounting strip boiler • Bag with fixings 	092537
Rear mounting frame for top pipe connection	092507
Bottom Pipework cover (HE26 only)	092527
Outside sensor for weather compensation	203207
Conversion set to Propane (G31) for HE26	075537
Conversion set to Propane (G31) for HE40C	075737
Intergas diagnostic software incl. USB interface cable (for Installers)	090407

4. INSTALLATION

4.1 Overall dimensions HE26

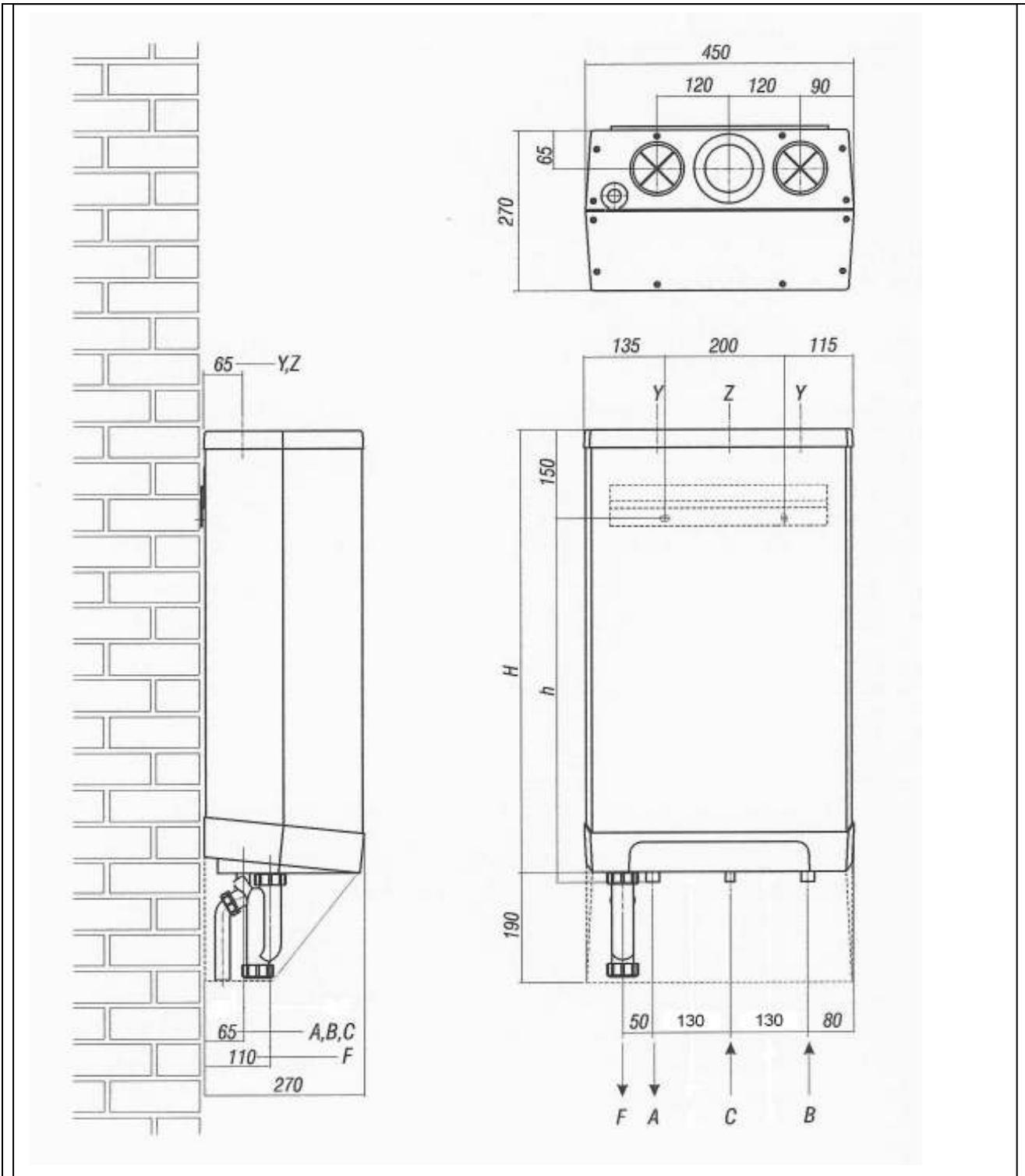

A=	CH flow	22 mm diameter	h=	670mm	InterSystem HE 26
B=	CH return	22 mm diameter			
C=	Gas	15 mm diameter	H=	810mm	InterSystem HE 26
			Z=	Flue gas outlet	80 mm diameter
F=	Condensate	32 mm dia (after trap 25 mm dia flexible)	Y=	Air supply inlet	80 mm diameter

4.2 Overall dimensions HE40C

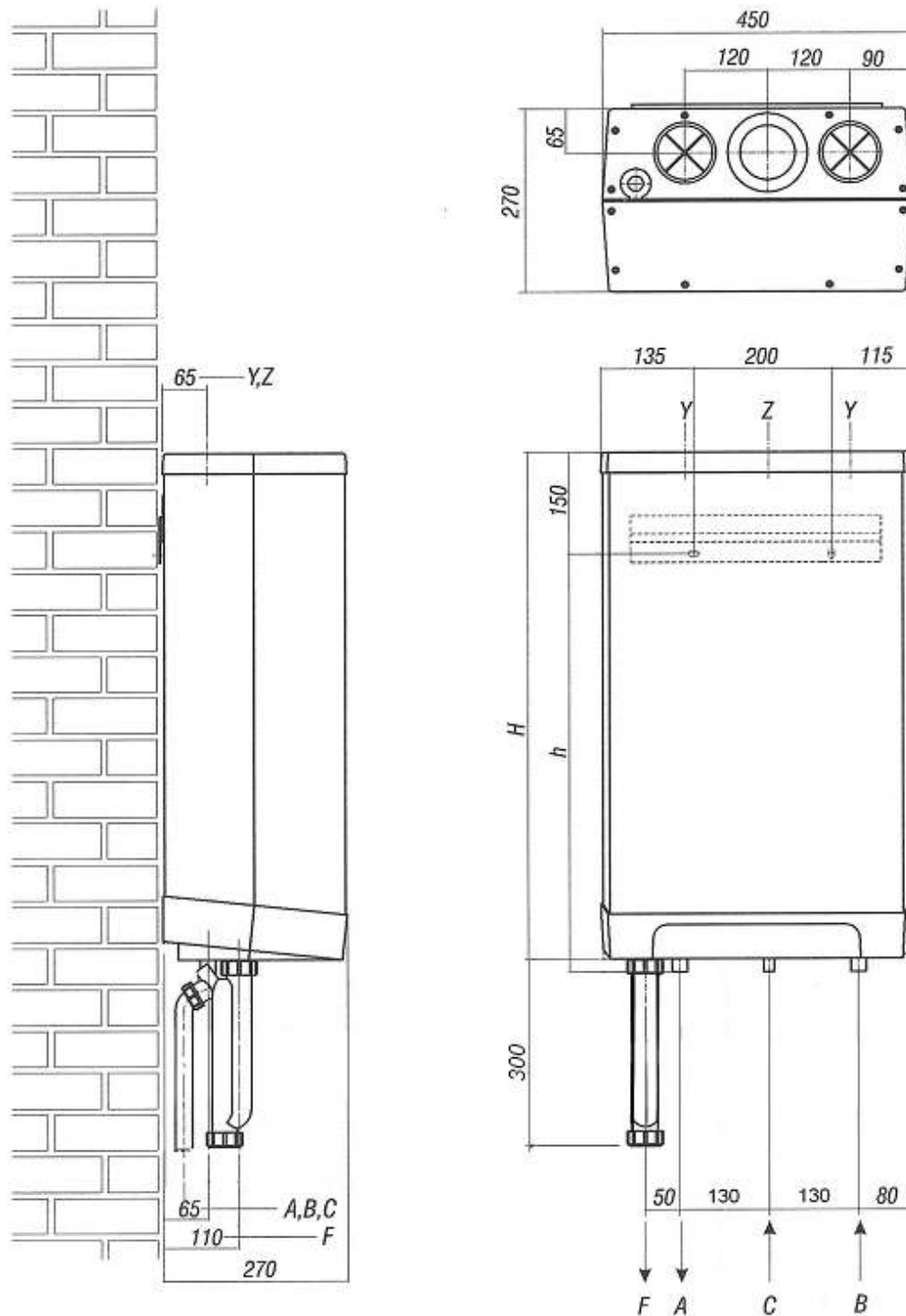

A=	CH flow	22 mm diameter	h=	670mm	
B=	CH return	22 mm diameter			
C=	Gas	15 mm diameter	H=	810mm	
			Z=	Flue gas outlet	80 mm diameter
F=	Condensate	32 mm dia (after trap 25 mm dia flexible)	Y=	Air supply inlet	80 mm diameter

4.3 Unpacking the appliance

1. Unpack the appliance.
2. Check the content of the packaging. This consists of:-
 - Appliance (A)
 - Mounting strip (B)
 - Condensate trap (C)
 - Installation Instructions
 - User Operating Instructions
 - Warranty card
3. Valve set (supplied separately with boiler) comprising 2 x 22mm isolation valves, 1 x gas valve.
4. Check the appliance for any damage: report damage to the Supplier immediately.

**CAUTION: This appliance should be lifted and handled by 2 people.
(Weight: 39 kg)**

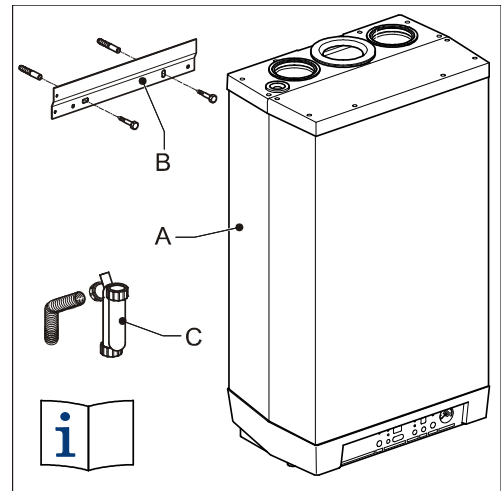

4.4 Additional dimensions

The diagram shown below gives additional dimensions primarily for the mounting arrangement using the **OPTIONAL** mounting bracket.

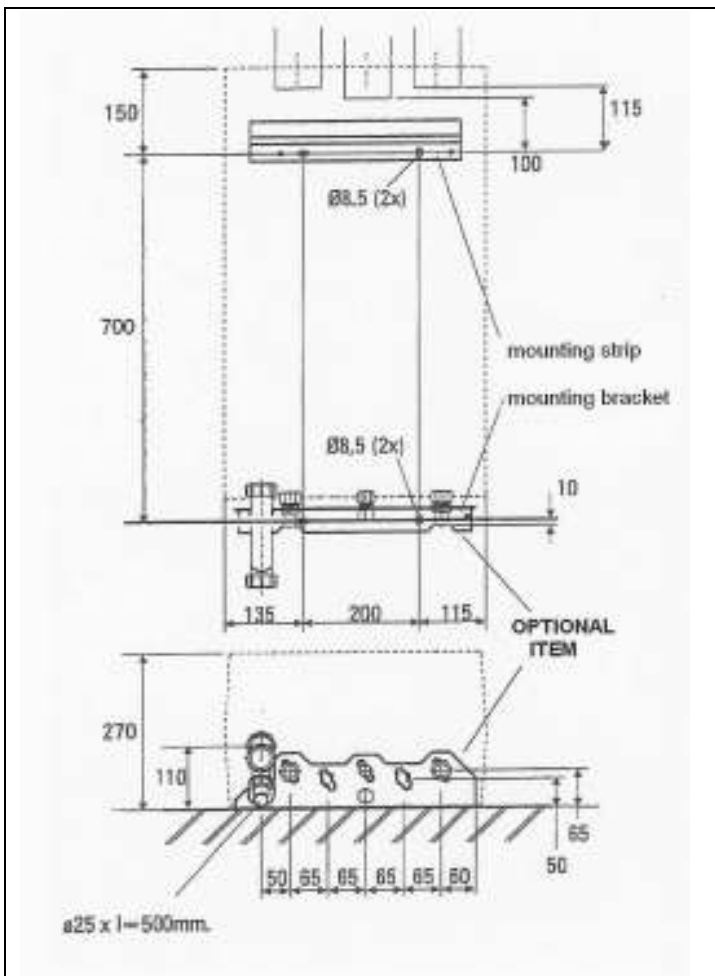

Note: The centre line of the hexagonal notch in the mounting bracket is also the centre line of the flue hole.

4.5 Boiler location

Clearances

Above casing	200mm min
Below casing	230mm min (HE26) 340mm min (HE40C)
RH	30mm min
LH	30mm min (in operation)
LH	140mm min (servicing, HE26)
Front	30mm min (in operation)
Front	450mm min (servicing)

Keep 50 mm free space above the front panel in order to be able to remove the front panel from the casing. Allow 140 mm on the left side for swinging out the expansion vessel during commissioning/service.

The appliance can be fitted to a mounting frame. The assembly or just the appliance should be mounted to a wall with sufficient bearing strength. In case of light wall constructions, resonance sounds may occur.

The appliance is suitable for mounting on a combustible wall (eg stud wall).

There must be an earthed electrical supply within a distance of 1 m from the appliance.

In order to avoid freezing of the condensate discharge, the appliance should be installed in a frost-free room.

4.5.1 Installation in a kitchen cupboard

Make sure there is sufficient ventilation above and below the appliance. When the appliance is placed in a small cupboard, ventilation openings of at least 50 cm² must be made.

4.5.2 Installation in an airing cupboard

Compartment ventilation is not required for a standard airing cupboard (eg 0.6 x 0.6 x 2.3m high).

4.5.3 Remove front panel

Remove the optional pipework cover and the front panel for carrying out work on the appliance as follows:-

1. Remove the pipework cover (A), if used, forwards.
2. Unscrew both recessed crosshead screws (B) at the bottom of the appliance.
3. Lift the front panel (C) vertically upwards and remove it forwards.

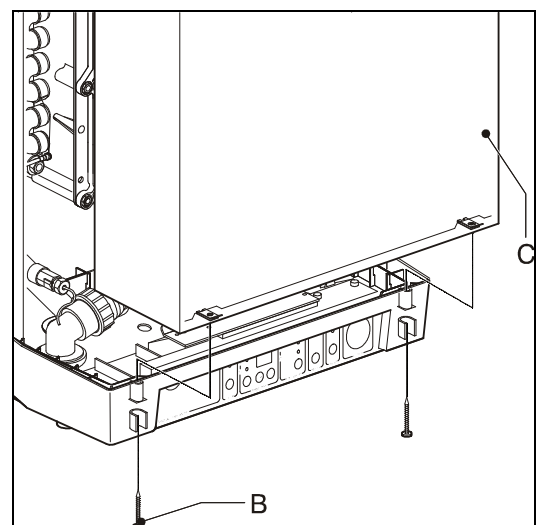
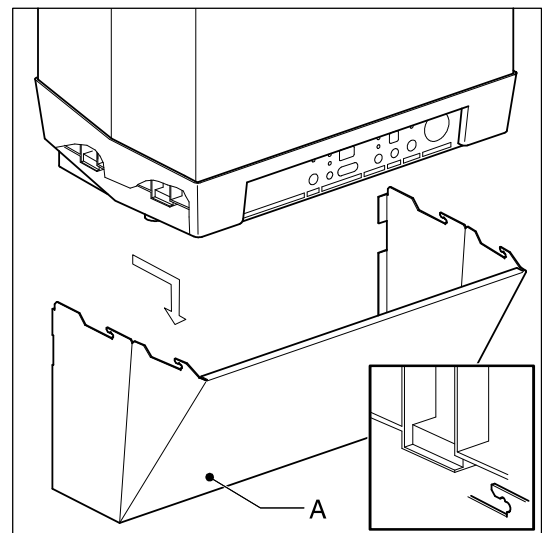
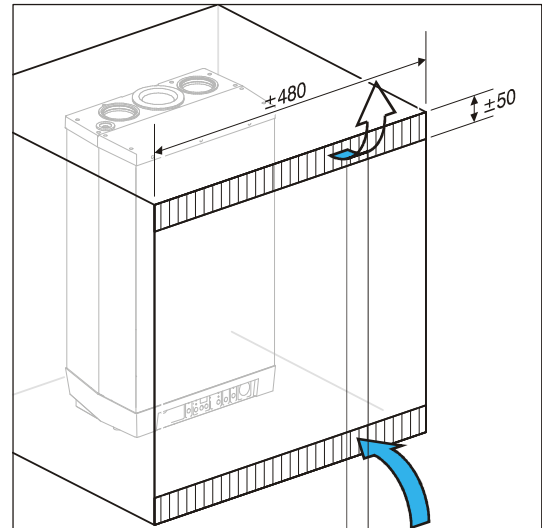
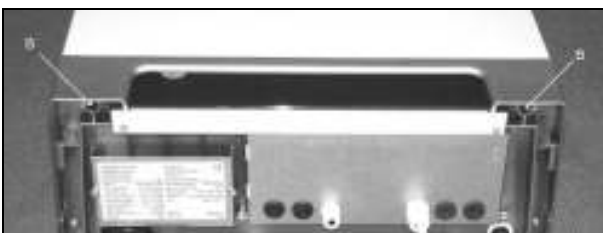

4.6 Mounting

Depending on the mounting option ordered, the following mounting methods are available:-

Mounting strip (A) alone,

OR mounting strip (A) and **optional** pipe mounting bracket (B),

OR rear mounting frame (C) and pipe mounting bracket (B), which are both **optional** items. This arrangement allows for vertical pipework behind the boiler.

Note that when the pipe mounting bracket is used, the pipes can be connected before installing the appliance.

4.6.1 Fitting the mounting strip

1. Fasten the mounting strip horizontally to the wall, using the screws and plugs supplied.
2. Mount the appliance.

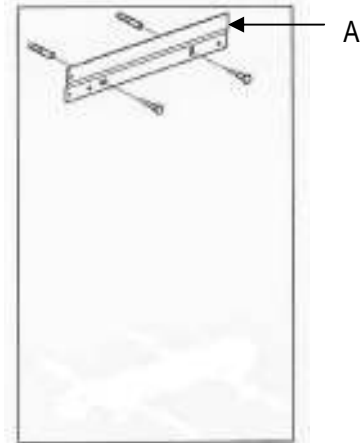

4.6.2 Fitting the mounting strip and the mounting bracket

1. Fasten the mounting strip and the pipe mounting bracket horizontally to the wall according to the drilling pattern, using the screws and plugs supplied.

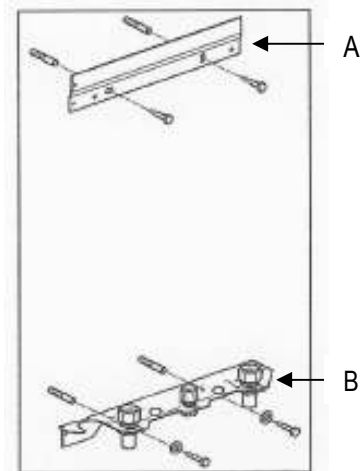

4.6.3 Fitting the rear mounting frame

1. Fasten the frame vertically to the wall, using screws and plugs.
2. Fasten the optional pipe mounting bracket to the frame using the fixings supplied.

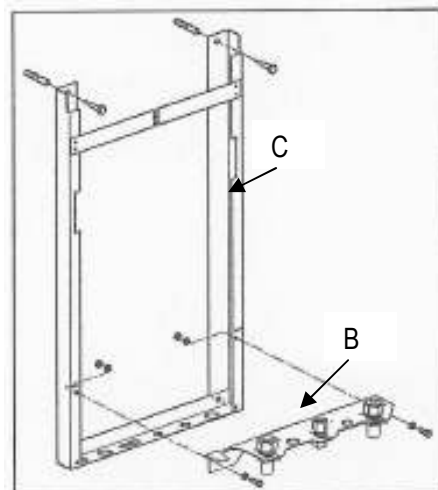

Caution

The appliance is wider than the frame by 20mm.

4.6.4 Installation connections

1. Make the various connections to the valves (see diagram).
2. Ensure a filling loop (between a domestic water pipe and the CH system) is installed for filling the central heating system.
3. For most installations, the flexible tube for the safety discharge will be long enough to fit into the condensate discharge waste pipe (see below). In cases where this does not apply, install a 15 mm copper safety discharge pipe to fit into the waste pipe (as shown in the diagram, §5.1) or run separately to a safe discharge position on the outside wall of the building.

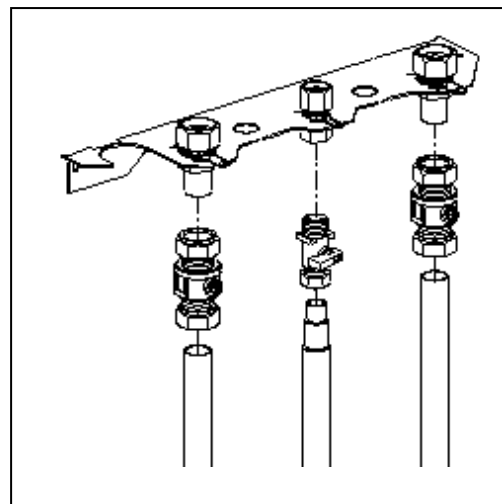

4.7 Mount the appliance

1. Check whether the compression rings of the optional mounting bracket are straight in the connectors.
2. Place the appliance: slide it top-down over the mounting strip. Make sure that the pipes simultaneously slide into the compression fittings of the optional mounting bracket.
3. The flexible tube from the condensate trap should be inserted into an open waste pipe of not less than 32 mm diameter. If connected to a soil pipe or waste system, the waste pipe must include a trap (similar to arrangement for washing machine). For more information on condensate disposal, please refer to §4.9.
4. The flexible tube from the pressure relief safety valve should be inserted into the waste pipe, or pushed over the 15 mm copper discharge pipe if provided.
5. Tighten the compression fittings to the optional mounting bracket.
6. Mount the air supply and the flue discharge.
7. Close the air supply opening that is not used with the plug supplied.

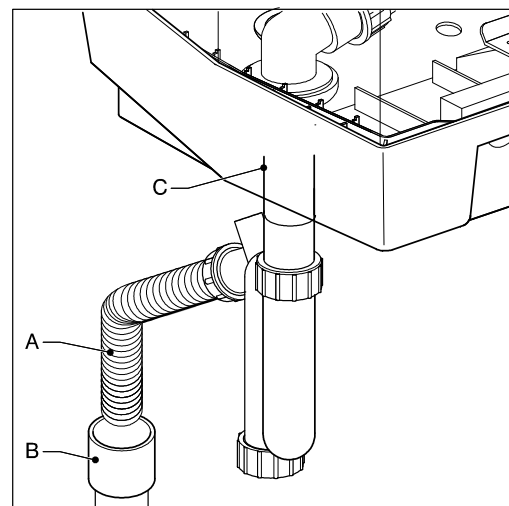

4.8 Fit the pipe work cover (option only for HE26)

1. Insert the four hooks of the pipe work cover in the slots of the appliance.
2. Slide the cover backwards, sliding the hooks into the slots and locking the cover.

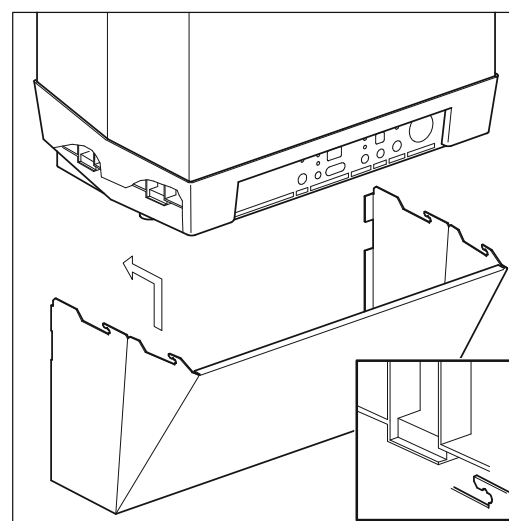

4.9 Condensate disposal

The appliance is provided with a 25 mm flexible pipe from its condensate trap. As given in §4.7, this should be inserted into an open waste pipe of not less than 32 mm diameter, together with the safety discharge pipe. The condensate is slightly acidic (pH between 3 and 6) and should be disposed of in the following ways, using suitable plastic waste pipe (Note: copper or steel must not be used):-

- internal stack pipe (see diagram)
- waste pipe (see diagrams)
- external drain or gully
- purpose made soak-away

The pipe work must incorporate a minimum fall of 2.5 degrees (or 44mm/metre) towards its point of termination. Condensate pipe work external to the property, or in an unheated space (eg a garage), must be protected against freezing through the use of pipe insulation and trace heating. Atmos can supply trace heating.

If an external drain or gully is used, then the open end of the pipe should be terminated below the grid level, but above the water level.

If a proprietary soak-away is used, install at least 1 metre away from the external wall and clear of foundations and services. The soak-away is buried in the ground and surrounded by limestone chippings to neutralise the condensate.

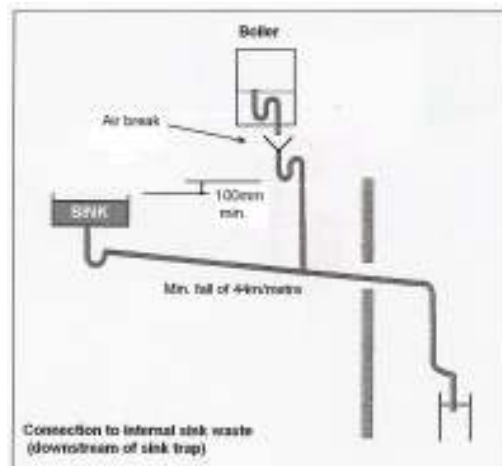
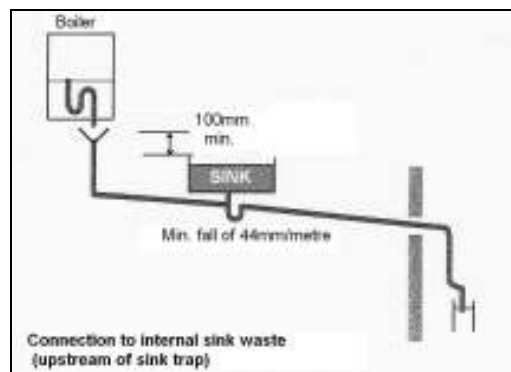
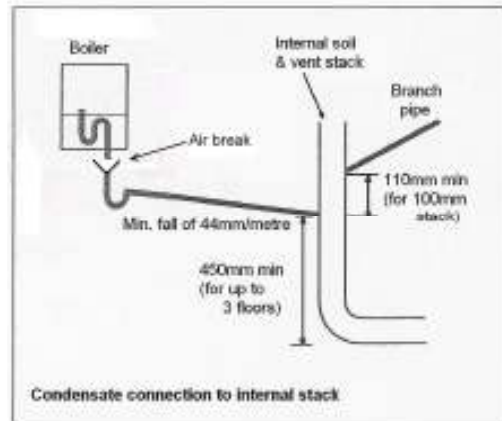

5. CONNECTIONS

5.1 Connect the CH system

1. Flush the CH system thoroughly.
2. Connect the flow and return pipes using the 22mm isolation valves. All pipes must be mounted tension-free in order to avoid ticking of the pipes.
Existing connections must not be twisted in order to avoid leaks at the connections with the external pipes.

The CH system should be provided with:-

- A filling loop in the return pipe directly below the appliance.
- A drain tap at the lowest point of the system.
- An expansion tank. The HE26 comes complete with 6 litre expansion tank. It may be necessary to fit an additional expansion tank.

5.1.1 Expansion vessel

The HE26 appliance is fitted with a 6 litre expansion vessel which is adequate for a system with a water volume not exceeding 100 litres, typically 8 radiators. For larger volume systems, an additional expansion vessel must be fitted. Atmos can supply a 12 litre or 18 litre Robokit.

The HE40C appliance is not fitted with an expansion vessel.

5.1.2 Thermostatic radiator valves

Building regulations require a room thermostat to be fitted on all installations. Do not fit a thermostatic valve on the radiators in the room where the thermostat is situated, otherwise the controls will not function correctly.

5.1.3 System bypass

A by-pass is not required for safe operation of the boiler. For heating systems where there are thermostatic valves on all radiators, or where there are other system flow restrictions such as zone valves, a by-pass should be fitted to reduce system noise and to protect the pump. The by-pass should comprise a proprietary by-pass valve with adjustable flow regulation, not a fixed setting valve. Atmos can supply this valve.

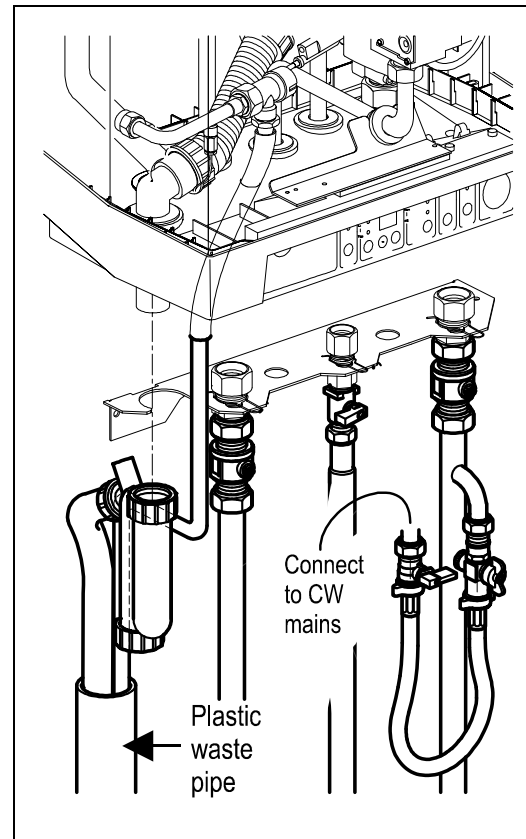

Note

The flexible tube from the pressure relief safety valve can be inserted directly into the waste pipe if suitably located. The flexible tube must be installed so that there are no sharp bends that kink the pipe and cause a restriction in the flow.